

DINergy™ MDP60-1C SERIES

AC - DC DIN RAIL MOUNTABLE POWER SUPPLY
INDUSTRIAL CONTROL EQUIPMENT



FEATURES

- UL / cUL / CE
- UNIVERSAL INPUT 85~264VAC
- SHORT CIRCUIT PROTECTION
- INTERNAL INPUT FILTER
- 3 YEARS WARRANTY



MODEL NO.	INPUT VOLTAGE	OUTPUT WATTAGE	OUTPUT VOLTAGE	OUTPUT CURRENT	EFF. (typ.)	EFF. (min.)
MDP60-12A-1C	85~264 VAC	60 WATTS	+ 12 VDC	5000 mA	84%	86%
MDP60-24A-1C	85~264 VAC	60 WATTS	+ 24 VDC	2500 mA	86%	89%

SPECIFICATION

All Specifications Typical At Nominal Line, Full Load, 25°C Unless Otherwise Noticed

GENERAL						
Characteristics	Conditions	min.	typ.	max.	unit	
Switching frequency	Vi nom, Io nom	55		90	KHz	
Isolation voltage	Input-Output	3000 / 4242			VAC / VDC	
	Input-FG	1500 / 2121			VAC / VDC	
	Output-FG	500 / 710			VAC / VDC	
Isolation resistance	Input-Output, @ 500VDC	100			MΩ	
Ambient temperature	Operating at Vi nom	-40		+ 71	°C	
Derating (see derating curve)	Vi nom, from +61 °C to +71 °C			2.5	% / °C	
Storage temperature	Non operational	-40		+ 85	°C	
Relative humidity	Vi nom, Io nom	20		95	% RH	
Temperature coefficient	Vi nom, Io min			± 0.03	% / °C	
MTBF	Bellcore Issue 6 @40°C, GB	5V model		498000	Hours	
		12V model		504000	Hours	
		24V model		520000	Hours	
		48V model		531000	Hours	
Altitude during operation	IEC 60068-2-13			4850	m	
Dimension	Screw terminal type	L90 x W40.5 x D114			mm	
Cooling	Free air convection					
Installation position	Vertical (other direction may derating using)					
Pollution degree		2				

DINergy™ MDP60-1C SERIES

INPUT SPECIFICATIONS						
Characteristics	Conditions		min.	typ.	max.	unit
Rated input voltage	Io nom		100		240	VAC
Absolute input max. range	Ta min ... Ta max, Io nom	AC in	85		264	VAC
		DC in	90		375	VDC
Input current	Vi : 115 / 230 VAC, Io nom			1060 / 590		mA
Rated input current	Vi : 85 VAC, Io nom				1500	mA
Line frequency	Vi nom, Io nom		47		63	Hz
Inrush current	Vi : 115 / 230 VAC, Io nom				20 / 40	A
Power dissipation	Vi : 230 VAC, Io nom	5V model		12.5		W
		12V model		9.0		W
		24V model		8.8		W
		48V model		7.8		W
Leakage current	Input-Output				0.25	mA
	Input-FG				3.5	mA

OUTPUT SPECIFICATIONS						
Characteristics	Conditions		min.	typ.	max.	unit
Output voltage accuracy (Adjusted before shipment)	Vi nom, Io max		0		+ 1	%
Minimum load	Vi nom		0			%
Line regulation	Io nom, Vi min ... Vi max				± 0.5	%
Load regulation	Vi nom, Io min ... Io nom				± 0.5	%
Voltage trim range	Vi nom, 0.8 Io nom	5V model	5		5.5	VDC
		12V model	12		14	VDC
		24V model	24		28	VDC
		48V model	48		55	VDC
Rated continuous loading	Vi nom	5V model	10 A @ 5Vdc / 9.0 A @ 5.5 Vdc			
		12V model	5 A @ 12Vdc / 4.25 A @ 14 Vdc			
		24V model	2.5 A @ 24Vdc / 2.1 A @ 28 Vdc			
		48V model	1.25 A @ 48Vdc / 1.08 A @ 55 Vdc			
Hold up time	Vi : 115 / 230 VAC, Io nom		20 / 30			ms
Turn on time	Vi nom, Io nom				1000	ms
	Vi nom, Io nom → with 7000 µF CAP				1500	ms
Rise time	Vi nom, Io nom				150	ms
	Vi nom, Io nom → with 7000 µF CAP				500	ms
Fall time	Vi nom, Io nom				150	ms
Transient recovery time	Vi nom, I ~ 0.5 Io nom				2	ms
Ripple & noise	Vi nom, Io nom, BW = 20MHz				50	mV
Power back immunity	Vi nom, Io nom 1 second	5V model	7.5			VDC
		12V model	18			VDC
		24V model	35			VDC
		48V model	63			VDC
Capacitor load	Vi nom, Io nom				7000	µF
DC ON indicator threshold at start up (Green LED)	Vi nom, Io nom	5V model	3.5		4.5	VDC
		12V model	9.0		10.8	VDC
		24V model	18		21.6	VDC
		48V model	37		43	VDC
Efficiency	Vi nom, Io nom, Po / Pi		Up to 89%, See model list and typ efficiency curve			

CONTROL AND PROTECTION						
Characteristics	Conditions		min.	typ.	max.	unit
Input fuse			T2A / 250VAC internal			
Internal surge voltage protection	IEC 61000-4-5		Varistor			
Rated over load protection	Vi nom (see typ current limited curve)		110		150	%

DINergy™ MDP60-1C SERIES

Characteristics	Conditions	min.	typ.	max.	unit
Power Rdy (for 24V model only)	Threshold voltage of contact closed (at start up)	18.8		19.6	VDC
Over voltage protection	Vi nom, Io nom (Auto Recovery)	5V model		6.8	VDC
		12V model	15	16.5	VDC
		24V model	30	33	VDC
		48V model	60	66	VDC
Output short circuit		Fold forward			
Degree of protection		IP20			

APPROVALS AND STANDARDS

UL / cUL	UL 508 Listed UL 60950-1, UL 1310 Class 2 Power (only 5V, 12V w/o Class 2) Recognized ISA 12.12.01(Class I, Division 2, Groups A, B, C and D)
CE	EN 61000-6-3, EN 55022 Class B, EN 61000-3-2, EN 61000-3-3 EN 61000-6-2, EN 55024, EN 61000-4-2 Level 4, EN 61000-4-3 Level 3 EN 61000-4-4 Level 4, EN 61000-4-5 L-N Level 3, L / N-FG Level 4 EN 61000-4-6 Level 3, EN 61000-4-8 Level 4, EN 61000-4-11 ENV 50204 Level 2, EN 61204-3
Vibration resistance	meet IEC 60068-2-6 (Mounting by rail: 10-500 Hz, 2G, along X, Y, Z each Axis, 60 min for each Axis)
Shock resistance	meet IEC 60068-2-27 (15G, 11ms, 3 Axis, 6 Faces, 3 times for each Face)

PHYSICAL CHARACTERISTICS

Case size	90 x 40.5 x 114 mm (3.6 x 1.59 x 4.49 inches)
Case material	Plastic
Weight	340 g
Packing	0.41 kg ; 40pcs / 17.5 kg / 2.16 CUFT

MECHANISM & PIN CONFIGURATION

mm [inch]

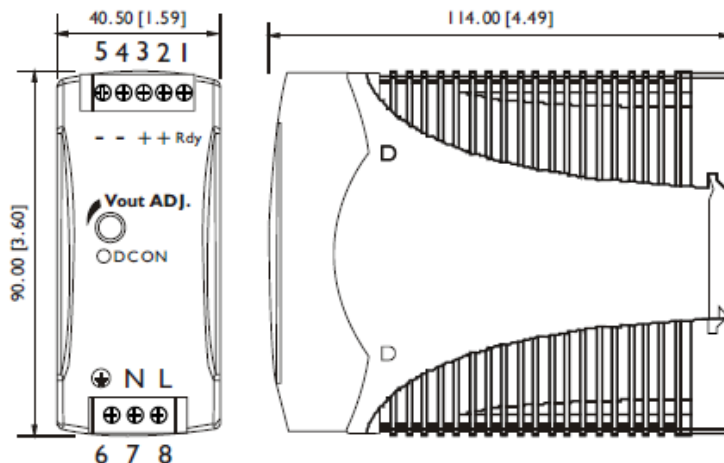

CONSTRUCTION

Easy snap-on mounting onto the DIN-Rail (TS35/7.5 or TS35/15), unit sits safely and firmly on the rail.

INSTALLATION

Ventilation / Cooling
Normal convection
All sides 25mm free space
For cooling recommended
Connector size range
Screw terminal:
AWG26-12 (0.2~2.5mm²) flexible / solid cable,
connector can withstand torque at maximum 5
pound-inches.
4~5 m/m stripping at cable end recommends
Use copper conductors only, 60 / 75°C

GENERAL TOLERANCE	
0.00[0.00] - 30.00[1.18]	±0.30[0.01]
30.00[1.18] - 120.00[4.72]	±0.50[0.02]

DINergy™ MDP60-1C SERIES

PIN ASSIGNMENT

PIN NO.	Designation	Description
1	RDY	DC OK output for relay (not connect except 24V model)
2	+	Positive output terminal
3	+	Positive output terminal
4	-	Negative output terminal
5	-	Negative output terminal
6	⏏	Ground this terminal to minimize high-frequency emissions
7	N	Input terminals (neutral conductor, no polarity at DC input)
8	L	Input terminals (phase conductor, no polarity at DC input)
	Vout ADJ.	Trimmer-potentiometer for Vout adjustment
	DC ON	Operation indicator LED

Fig. 1 Rdy connection

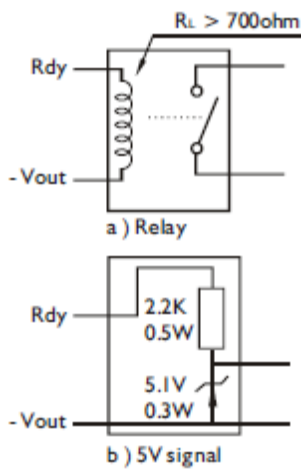

CIRCUIT SCHEMATIC

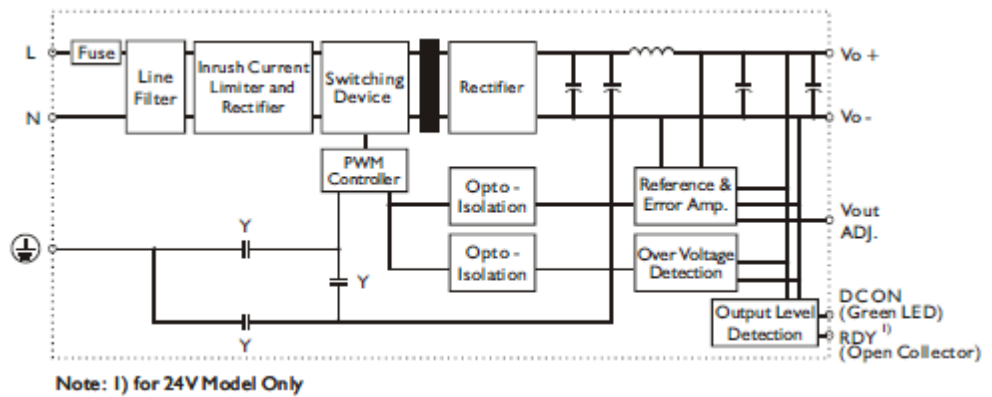

TYP. CURRENT LIMITED CURVE

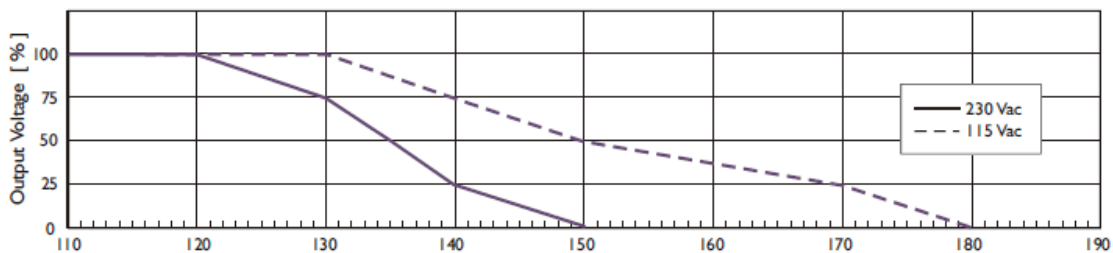

DERATING CURVE

