

NOTES:

1. ALL UNITS ARE cUL LISTED & DESIGNED ACCORDANCE WITH INDUSTRY STANDARDS.
2. TRANSFORMERS ARE DRY-TYPE, CLASS AA, ENCAPSULATED NEMA 3R ENCLOSED FOR INDOOR / OUTDOOR USE.
3. TRANSFORMERS ARE WALL / MACHINE MOUNTABLE VIA THE ATTACHED BRACKETS.
4. TRANSFORMERS ARE CONSTRUCTED BASED UPON A 40°C AMBIENT ENVIRONMENT.
5. MAINTAIN 1" CLEARANCE FROM ALL LIVE PARTS.
6. PAINT COLOR IS GREY.

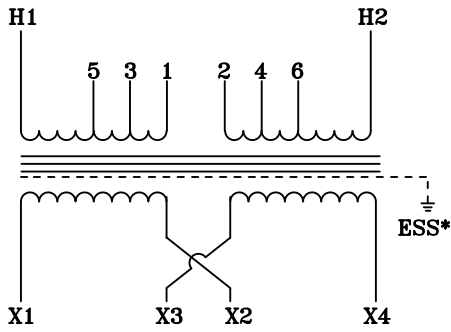

TYPICAL WIRING DIAGRAM

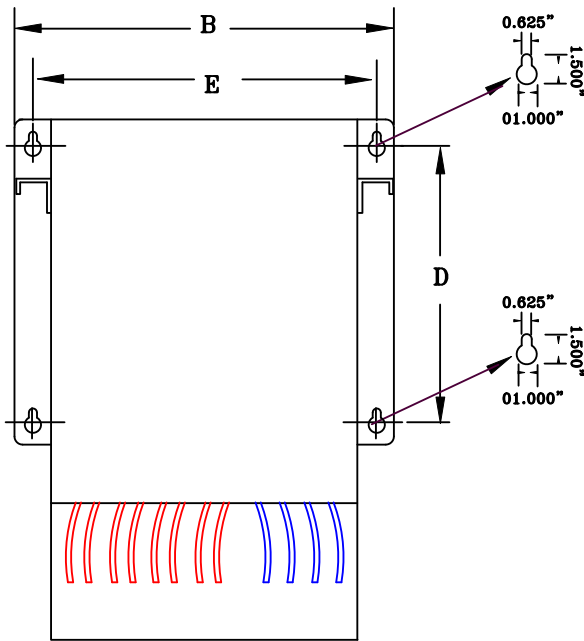

FRONT VIEW

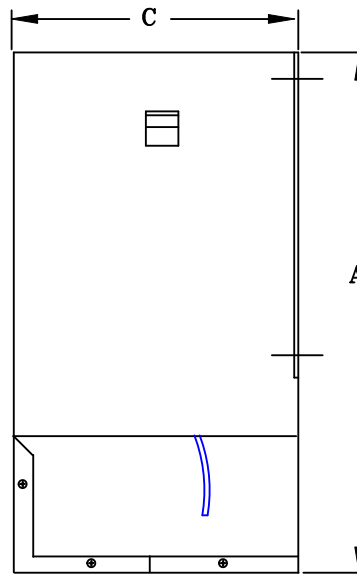

SIDE VIEW

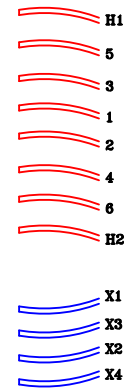

TERMINAL VIEW

APPROXIMATE DIMENSIONS (INCHES)

KVA	A	B	C	D	E	F	HARDWARE	MTG SLOTS	ENCLOSURE	lbs.	WEATHER SHIELD	TERMINAL TYPE
25.0	19.50	17.75	11.25	8.00	15.75	----	1/2-13	0.625" x 1.50"	DE-25K	300	N/A	LEADs

* ELECTROSTATIC SHIELD GROUNDED TO TRANSFORMER CASE AT FACTORY (IF APPLICABLE)

DRAWINGS
 APPROVAL
 RECORD
 OTHER

PRIMARY VOLTAGE	208	CUST.	XXXXXXXX	
SECONDARY VOLTAGE	120 x 240	JOB		
TEMPERATURE RISE IN °C	115	CATALOG		
WINDINGS & TERMINALS	<input type="checkbox"/> ALUMINUM <input checked="" type="checkbox"/> COPPER	NOTE	XXXXXXXX	
FREQUENCY HERTZ	60	BY	ENG. LOG.	TITLE
PRIMARY TAPS	188, 193, 198, 203, 213, 218	DATE		1-PHASE, 600 VOLT CLASS ISOLATION DRY TYPE TRANSFORMER
	REV	MFG. LOG.	DWG. NO.	
	DATE:	DWG. FILE	N3F877L25-WT	