

NOTES:

1. ALL UNITS ARE cUL LISTED & DESIGNED ACCORDANCE WITH INDUSTRY STANDARDS.
2. TRANSFORMERS ARE DRY-TYPE, CLASS AA, VENTILATED, OPEN-STYLE ASSEMBLY FOR INDOOR/CONTROL PANEL USE.
3. TRANSFORMER ARE BASE MOUNTED.
4. TRANSFORMERS ARE CONSTRUCTED BASED UPON A 40°C AMBIENT ENVIRONMENT.
5. MAINTAIN 1" CLEARANCE FROM ALL LIVE PARTS.

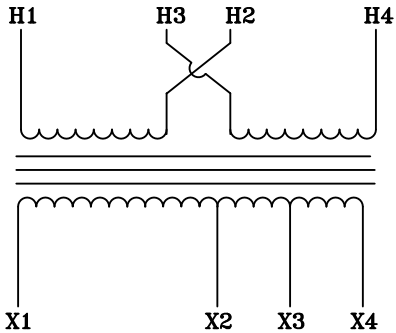

TYPICAL WIRING DIAGRAM

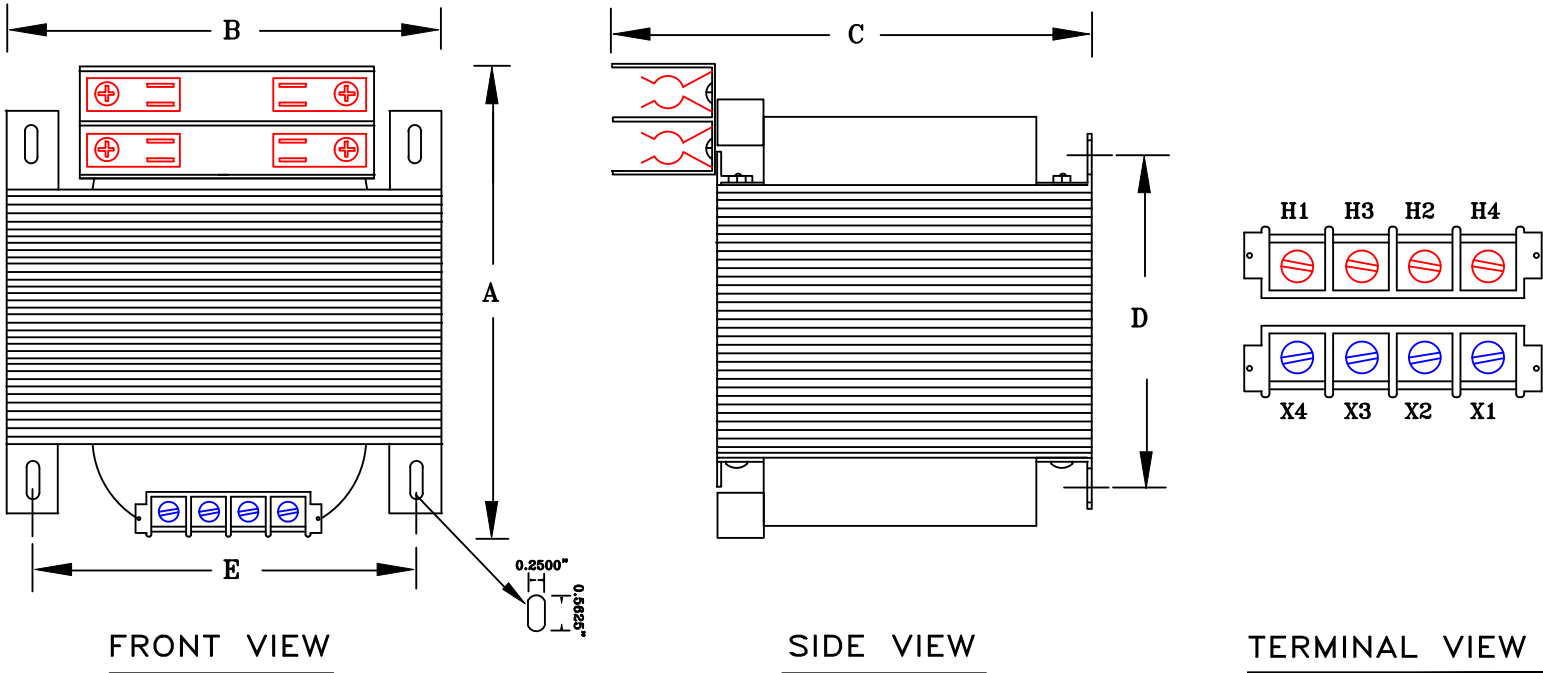

APPROXIMATE DIMENSIONS (INCHES)

KVA	A	B	C	D	E	3-POLE PRIMARY FUSE BLOCK	PRIMARY COVER	SECONDARY COVER	HARDWARE	(4) MTG SLOTS	STEEL	STACK	WEIGHT
0.750	7.50	6.50	7.50	2.75	3.75	INCLUDED	INCLUDED	INCLUDED	1/4-20	0.250" x 0.562"	EI-212	3.62	35

DRAWINGS
 APPROVAL
 RECORD
 OTHER

PRIMARY VOLTAGE	380-400-415	CUST.	XXXXXXXX	
SECONDARY VOLTAGE	120	JOB		
TEMPERATURE RISE IN °C	55	CATALOG		
WINDINGS & TERMINALS	<input type="checkbox"/> ALUMINUM <input checked="" type="checkbox"/> COPPER	NOTE	XXXXXXXX	
FREQUENCY HERTZ	50/60	BY	ENG. LOG.	TITLE
PRIMARY TAPS	NONE	DATE		1-PHASE, 600 VOLT CLASS CONTROL DRY TYPE TRANSFORMER
	REV	MFG. LOG.	DWG. NO.	
	DATE:	DWG. FILE	A976MT750-2FB	