

**NOTES:**

1. ALL UNITS ARE cUL LISTED & DESIGNED ACCORDANCE WITH INDUSTRY STANDARDS.
2. TRANSFORMERS ARE DRY-TYPE, CLASS AA, ENCAPSULATED NEMA 4 ENCLOSED FOR INDOOR / OUTDOOR USE.
3. TRANSFORMERS ARE WALL / MACHINE MOUNTABLE VIA THE ATTACHED BRACKETS.
4. TRANSFORMERS ARE CONSTRUCTED BASED UPON A 40°C AMBIENT ENVIRONMENT.
5. MAINTAIN 1" CLEARANCE FROM ALL LIVE PARTS.
6. PAINT COLOR IS RAL# 7042.

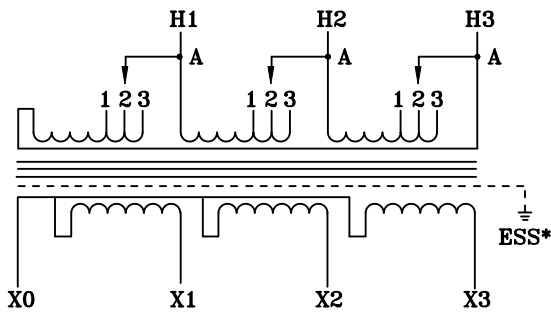

TYPICAL WIRING DIAGRAM

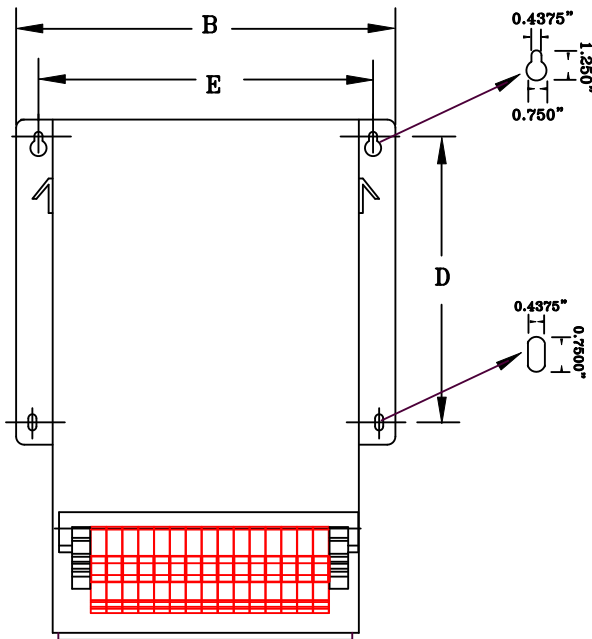

FRONT VIEW

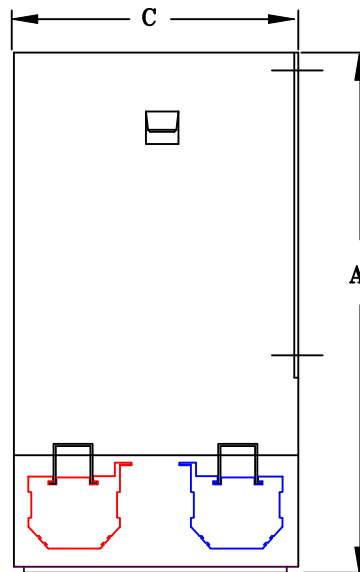

SIDE VIEW

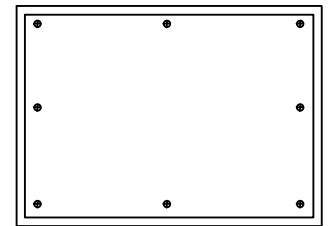

BOTTOM VIEW

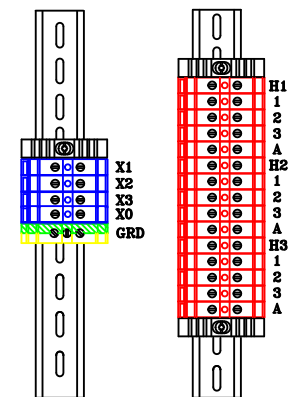

TERMINAL VIEW

**APPROXIMATE DIMENSIONS ( INCHES )**

KVA	A	B	C	D	E	F	HARDWARE	MTG SLOTS	ENCLOSURE	lbs.	WEATHER SHIELD	TERMINAL TYPE
6.0	15.25	14.12	10.50	8.50	12.75	----	3/8-16	0.437" x 0.750"	N10-N4	150	N/A	TBS

\* ELECTROSTATIC SHIELD GROUNDED TO TRANSFORMER CASE AT FACTORY ( IF APPLICABLE )

DRAWINGS  
 APPROVAL  
 RECORD  
 OTHER

INPUT VOLTAGE	480 DELTA	CUST	XXXXXXXXXX
OUTPUT VOLTAGE	208Y/120	JOB	
TEMPERATURE RISE IN °C	130	CUST #	
WINDINGS & TERMINALS	<input type="checkbox"/> ALUMINUM <input checked="" type="checkbox"/> COPPER	NOTE	HAZARDOUS LOCATION ( CLASS I, DIVISION II, GROUPS A-D )
FREQUENCY IN HERTZ	60	BY	3-PHASE, 600 VOLT CLASS AUTO DRY TYPE TRANSFORMER
INPUT TAPS	456, 504	DATE	
POWERTRAN	REV	MFG. LOG.	DWG. NO.
	DATE:	DWG. FILE	3N4F408FST6