

TYPICAL WIRING DIAGRAM

NOTES:

1. ALL UNITS ARE cUL LISTED & DESIGNED ACCORDANCE WITH INDUSTRY STANDARDS.
2. TRANSFORMERS ARE DRY-TYPE, CLASS AA, VENTILATED, OPEN-STYLE ASSEMBLY FOR INDOOR/CONTROL PANEL USE.
3. TRANSFORMER ARE BASE MOUNTED.
4. TRANSFORMERS ARE CONSTRUCTED BASED UPON A 40°C AMBIENT ENVIRONMENT.
5. MAINTAIN 1" CLEARANCE FROM ALL LIVE PARTS.

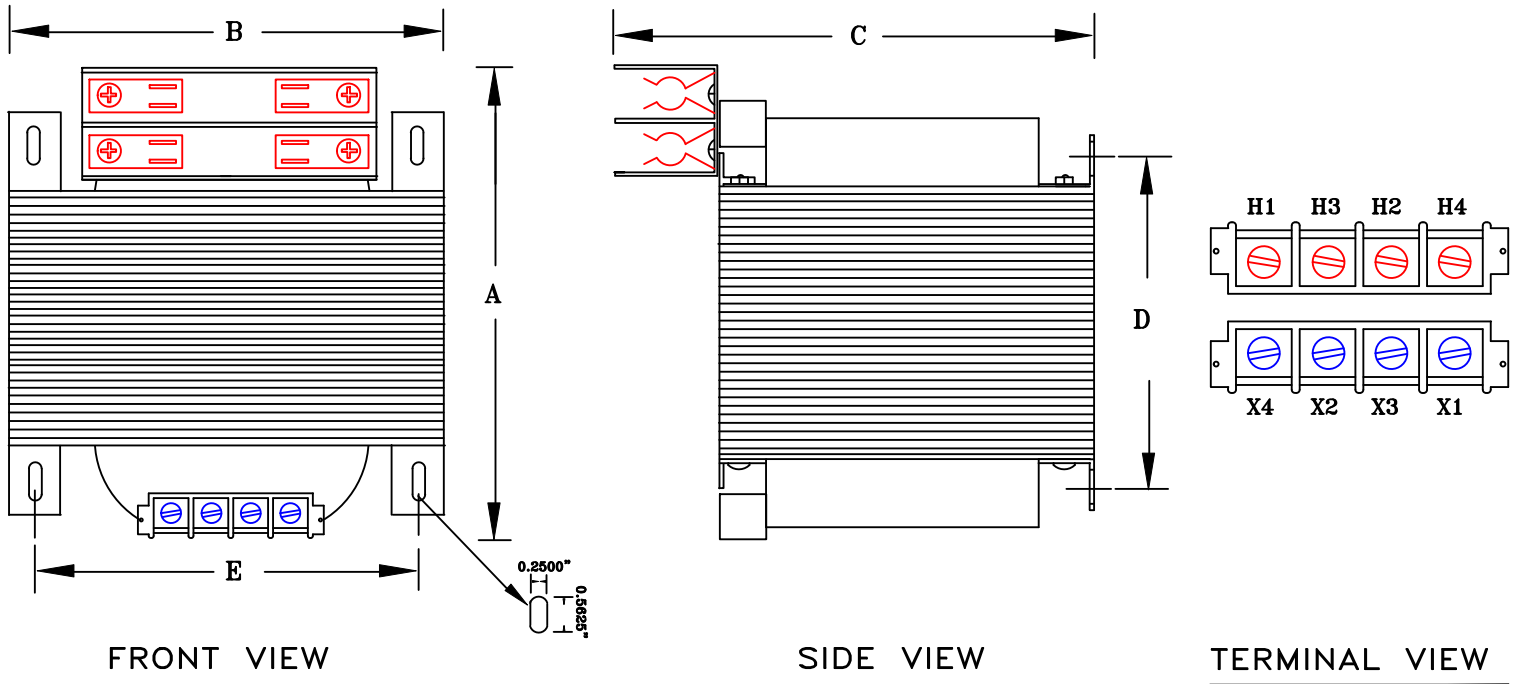

FRONT VIEW

SIDE VIEW

TERMINAL VIEW

APPROXIMATE DIMENSIONS (INCHES)

KVA	A	B	C	D	E	2-POLE PRIMARY FUSE BLOCK	PRIMARY COVER	SECONDARY COVER	HARDWARE	(4) MTG SLOTS	STEEL	STACK	WEIGHT
0.500	5.50	5.25	5.75	3.63	4.38	INCLUDED	INCLUDED	INCLUDED	1/4-20	0.250" x 0.562"	EI-175	2.50	20

DRAWINGS
 APPROVAL
 RECORD
 OTHER

PRIMARY VOLTAGE	240 x 480	CUST.	XXXXXXXX										
SECONDARY VOLTAGE	120 x 240	JOB											
TEMPERATURE RISE IN °C	55	CATALOG											
WINDINGS & TERMINALS	<input type="checkbox"/> ALUMINUM <input checked="" type="checkbox"/> COPPER	NOTE	XXXXXXXX										
FREQUENCY HERTZ	50/60	BY	ENG. LOG.	TITLE	1-PHASE, 600 VOLT CLASS CONTROL DRY TYPE TRANSFORMER								
PRIMARY TAPS	NONE	DATE											
POWERTRAN	REV	MFG. LOG.	DWG. NO.		A134MT500-2FB								
	DATE:	DWG. FILE											